

DIMENSIONS ARE IN INCHES

SIZE	18	20	24	30
A	28 1/4	30 1/2	35 3/4	43 9/16
B	1 9/16	1 11/16	1 7/8	1 3/4
C	32 7/16	36 15/16	41 7/8	45 7/8
D	1 1/4	1 1/4	1 3/8	1 3/8
E	14	18	18	24
F	22 3/4	25	29 1/2	36
G	8 1/2	9 5/8	11 7/8	14 7/8

Item	Description	QTY.	MAT'L
1	Frame	1	CI
2	Seat Ring	1	BRZ
3	Yoke	1	CI
4	Plug	1	CI
5	Resilient Seat	1	BUNA-N
6	Stem	1	SS
7	HHCS	4	SS
8	HHCS	1	SS
9	Nut	1	SS
10	Sleeve Coupling	1	STEEL/SS

Notes:

- Bubble tight resilient-to-bronze seating
- NSF Approved 2 part epoxy coating
- Valve Flanges must be level for proper operation
- 125# ANSI flange
 - Only the number of holes specified in the chart are used

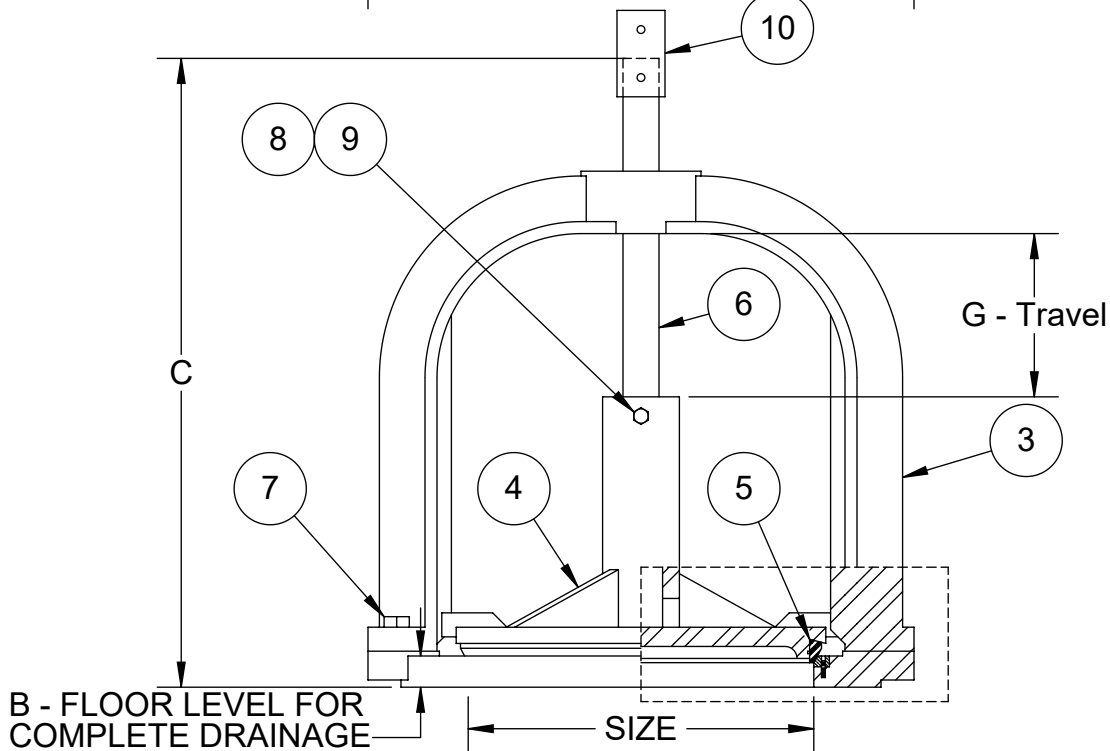
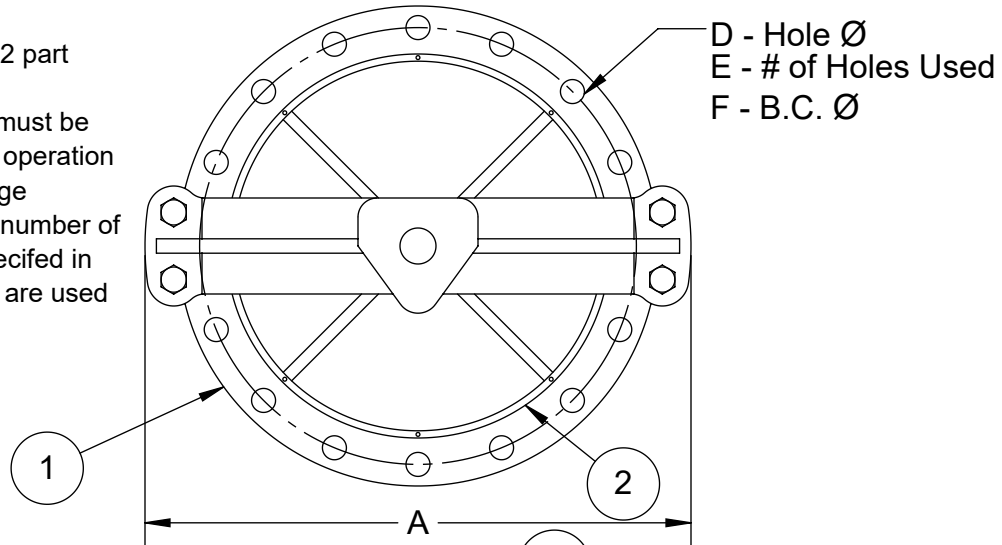

www.TroyValve.com

PHONE: 1-570-297-2125

26A- DO NOT SCALE DRAWING

TITLE:

CI Sliding Stem Mud Valve 18" - 30"

MAT'L: CI

DATE: 3/25/2021

PART NO:

A25600RB SLIDING

DWN.

TE

PAGE: