

Item	Description	QTY.	MAT'L
1	Yoke Coupling	1	CI
2	Extension Stem	2	STEEL/SS
3	3/8-16 HHCS	3	SS
4	3/8-16 Locknut	3	SS
5	Sleeve Coupling	1	STEEL/SS

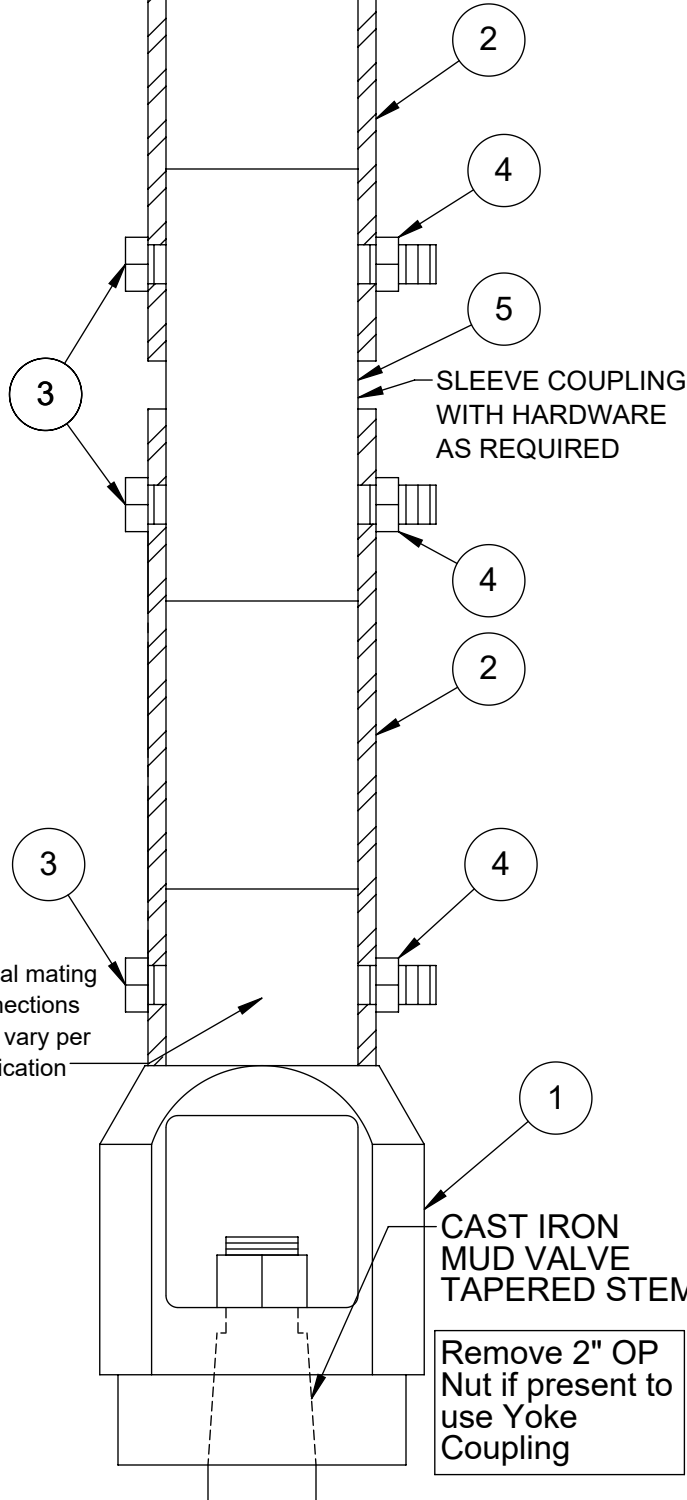

EXTENSION STEM

L = _____

MAT'L = _____

DIA = _____

L = LENGTH AS MEASURED FROM THE FACE OF THE FLANGE TO THE TOP OF THE OPERATOR

*** ACTUAL REQUIRED DIMENSIONS IN THE FIELD MAY VARY FROM THE DIMENSIONS SUPPLIED TO TROY VALVE. BE ADVISED THAT FIELD ADJUSTMENTS MAY BE REQUIRED.**

SOLID NUT

- CAST IRON
- STAINLESS STEEL

HANDWHEEL

SIZE = _____

MAT'L = _____

FLOORSTAND

- DUCTILE IRON
- 304SS 316SS
- NRS INDICATING A25655
- NON-INDICATING A25650
- OTHER _____

YOKE COUPLING

CAST IRON



www.TroyValve.com

PHONE: 1-570-297-2125

1EB- DO NOT SCALE DRAWING

TITLE:

2"+ Ext. Stem Assy. w/Yoke Coupling

MAT'L: Varies

DATE: 10/16/2020

PART NO:

ESPY-103

DWN.

TE

PAGE: