

TROY VALVE

T I M E S

VOL. 3 | MAY 2016

What's New at Troy Valve?

There's always something new at Troy Valve. Here's the latest scoop!

Spring has sprung and the leaves are finally back on the trees here in Troy, PA. As the scenery around town changes, so, too, do a few things at Penn-Troy Manufacturing. Here is a quick glance at the newest developments at the factory.

Over 500 Days Accident Free

We recently celebrated the tremendous accomplishment of going 500 straight days without lost time due to a work-related incident. This is a true testament to the workers in the shop keeping their work stations clean and clear of hazards as well as their observance of our safety procedures. For their efforts, the entire shop was rewarded with lunch from the local pizza shop.

Indicating a Revolution!

As you will read inside this issue, we have developed a new way to indicate the position your valves are in while you're operating them. Our new, ground-level position indicator can be placed in a floor box, in a valve box, on a stem guide, and even on a floor stand.

Compact, durable, water resistant, highly accurate, and useful for indicating up to 9,999 turns, this indicator fits a wide range of uses and will revolutionize the way you look at – and for – indicators. And we need your help in naming it! See this issue's contest inside for your chance to help us name this product.

New Whitepapers

We steadily have been adding to our library of whitepapers over the past year. The newest features Counterweighted Flap Valves. These informative whitepapers are a quick read loaded with useful information and are ideal for helping an engineer decide on a specification or compare products to

weigh pros and cons. A popular download in spring is always the Hydrostatic Pressure Relief Valve whitepaper. You may download all of our available whitepapers from our website.

A September to Remember

Preparations are underway for a very busy September 2016. At the beginning of the month, Penn-Troy's Bicera line of products will send a sales contingent to Hamburg Germany for the SMM trade fair. This is the world's largest trade fair for the marine industry, and we are excited about the opportunities and contacts we are sure to cultivate on this epic journey. Not long after our return from Europe, we will be packing our bags for New Orleans and the annual WEFTEC® show. This year is going to feature an exciting exhibit for us as we expect to have a few new products on display. Customers will have the opportunity to see in person the results of their feedback as well as our hard work and determination to not only supply a great product but also to manufacture trust.



Wall and Floor Hydrostatic Pressure Relief Valves

In this issue of the Troy ValveTimes, we will spotlight a popular spring product: Wall and Floor Hydrostatic Pressure Relief Valves. As new construction projects begin this season, some of the first areas of jobs to be installed are in-ground tanks. To avoid risk of tanks heaving and cracking under pressure from rising levels of ground water, we suggest the installation of Floor and/or Wall Pressure Relief Valves. Troy Valve offers a superior design that employs resilient-to-bronze seating for maximum durability and consistent seating that is available in stainless steel or epoxy-coated cast iron. For more information, along with some design considerations, please visit our website ... and download our whitepaper on the subject while you're there.

Product Spotlight



MADE IN THE USA

▶ Employee Recognition Corner



Kim Perry
Inside Sales Manager

How long have you worked at Penn-Troy?
18 years

What is your position?
Inside Sales Manager

What do you enjoy most about your job?
Every day is a little different. I like being in contact with our customers, from quoting to order entry — all the way to following up on jobs.

What are your hobbies?
Decorating my home. Planting flowers in the spring. Being with my children, and, now, my new granddaughter.

Do you have a vacation ritual or location?
All-inclusive resorts in the Caribbean.

What is your favorite movie?
I don't really have a favorite.

What is item #1 on your bucket list?
Owning a cottage on the Finger Lakes.

Do you have any hidden talents?
No, not really.

Family?
Married 24 years. Two children (Todd and Michelle). We are empty nesters now.

How do you unwind outside of work?
I enjoy spending weekends with family and friends.

▶ Volume 3 Contest

Name our newest product! Troy Valve is introducing our new, indicating floor box/valve box, and we want YOU to name it for us. Submit your best ideas (limit: three entries per customer), and the staff at Troy Valve will vote on their favorite. The winning entry will be the permanent name of our new indicator! Submit your entry to todd@troyvalve.com. The runner up will receive a token of our appreciation, and we will pick a few of the suggestions to publish in a future issue of the times.

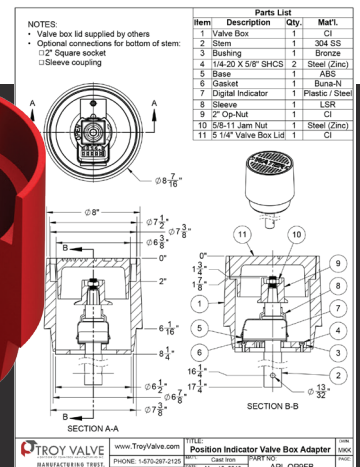

▶ A Message From the President

Thank you once again for taking the time to read our quarterly newsletter, the Troy Valve Times. Spring is in the air, our industry is coming alive, and Troy Valve is introducing a new product. In this issue, we are unveiling our new, Ground Level Position Indicator assembly. We are excited to offer the first digital-reading GLPI in our industry. Also, please take a look at our Pressure Relief Valve section as we highlight the critical sealing feature of this important valve.

As we move into our busy season, let me personally wish you and your business all the best. We all have a common goal of water quality, and this is an exciting time to be involved. Most important, however, make sure you make some time for a few rounds of golf or whatever your summer hobby may be.

Sincerely,

Mark Powers

Mark Powers
President and Chief Executive Officer



▶ Volume 2 Contest Winners

In Volume 2 of the *Troy Valve Times*, we asked our readers to send us questions about the Troy Valve sales staff. We thank everyone for their submissions and have selected a few questions to publish below:

Q: Does Troy perform their own casting and machining in house or does it use a third party? If they are performed by a 3rd party are they done in a domestic or foreign facility?

Brian Mannon of C. I. Thornburg Co., Inc.

Troy Valve no longer operates its own foundry. We currently have a number of domestic and foreign foundries that we work with for our castings. However, we do all of the machining, testing, painting and shipping of all of our products here at our factory in Troy, Pennsylvania.

Q: I had an order with you guys late last year, and my customer and I were very pleased by it. I was just hoping to maybe get a catalog or some other literature from you guys, so that I will hopefully know more and be able to place more orders with you in the future.

Jackson Scott, Inside Sales at HD Supply Waterworks

I'm glad to hear that you and your customer were pleased with your order. We hope we can work together soon on another job. We will get some literature out to you soon. We are working on getting our new catalog together and will send out an email as soon as it's available. In the meantime, please bookmark our website for quick access to all of our products.

Q. Does Troy have an option to make their floor stands 12" taller?

Jim Steele of Rawdon Myers Inc.

Yes, we can fabricate all sorts of configurations not only for floor stands but also for a multitude of products, such as extensions, guides, and brackets. If you would like to customize the specifications of a Troy Valve product, please talk with your sales representative, who can provide you with the details you need.

Just a few of our Non Rising stem Mud Valves in inventory



Cast Iron Mud valves with custom mesh cages as a special request

16 inch cast 316 stainless steel mud valves ready for deliver



Custom length Floor Hydrostatic Pressure Relief Valves



Extensions made from 304 stainless steel schedule 40 pipe

