

DIMENSIONS ARE IN INCHES								
SIZE	4	6	8	10	12	14	16	18
A	12	12	12	12	18	18	*	*
B	18	18	18	18	24	24	*	*
CONE Ø	12	12	12	12	18	18	18	24

* TBD at time of quote

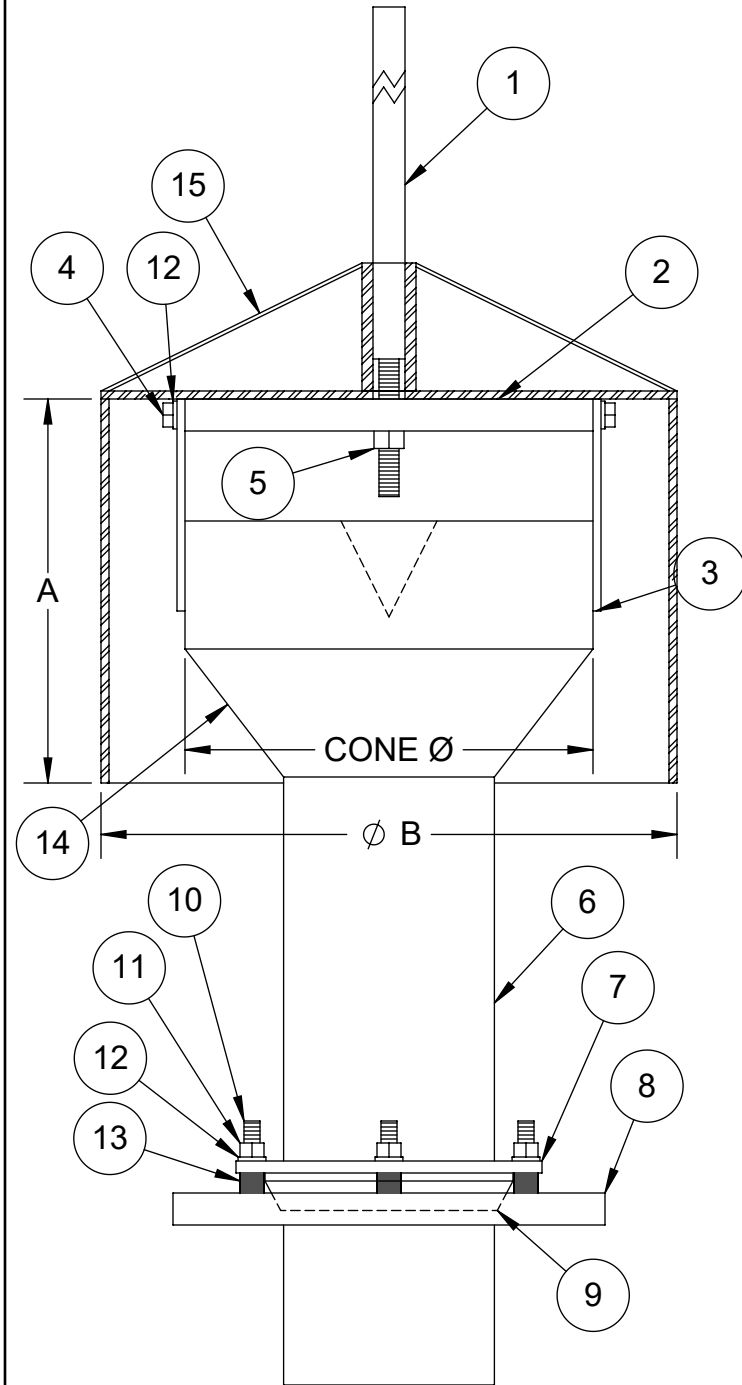

ITEM	DESCRIPTION	QTY.	MAT'L
1	Operating Stem	1	SS
2	Bail Crossbar	1	SS
3	Bail Riser	2	SS
4	HHCS	2	SS
5	Jam Nut	1	SS
6	Slip Tube	1	SS
7	Compression Ring	1	SS
8	Companion Flange	1	CI/SS
9	Split Gasket	1	BUNA-N
10	Stud	Varies	SS
11	Hex Nut	Varies	SS
12	Lock Washer	Varies	SS
13	Tension Washer	Varies	SS
14	Cone Adapter	1	SS
15	Scum Baffle	1	SS

Notes:

- Stem allows for minor adjustment
- Hardware material is determined by Slip Tube material
- V-Notch aids to reach Low Water and regulate flow
- Minimum 12" from Low Water Level to Flange

SLIP TUBE & SCUM BAFFLE

- 304SS
- 316SS

COMPANION FLANGE

- CAST IRON
- 304SS
- 316SS

V-NOTCH

- REQUIRED
- NOT REQUIRED

RISER PIPE NOMINAL SIZE



www.TroyValve.com

PHONE: 1-570-297-2125

22A- DO NOT SCALE DRAWING

TITLE:

Slip Tube Assembly With Cone and Scum Baffle

MAT'L: See Above

DATE: 3/9/2021

PART NO:

MTELEVLV-4

DWN.

TE

PAGE: