

ITEM	DESCRIPTION	QTY.	MAT'L
1	Operating Stem	1	SS
2	Bail Crossbar	1	SS
3	Bail Riser	2	SS
4	HHCS	2	SS
5	Jam Nut	1	SS
6	Slip Tube	1	SS
7	Compression Ring	1	SS
8	Companion Flange	1	CI/SS
9	Split Gasket	1	BUNA-N
10	Stud	Varies	SS
11	Hex Nut	Varies	SS
12	Lock Washer	Varies	SS
13	Tension Washer	Varies	SS

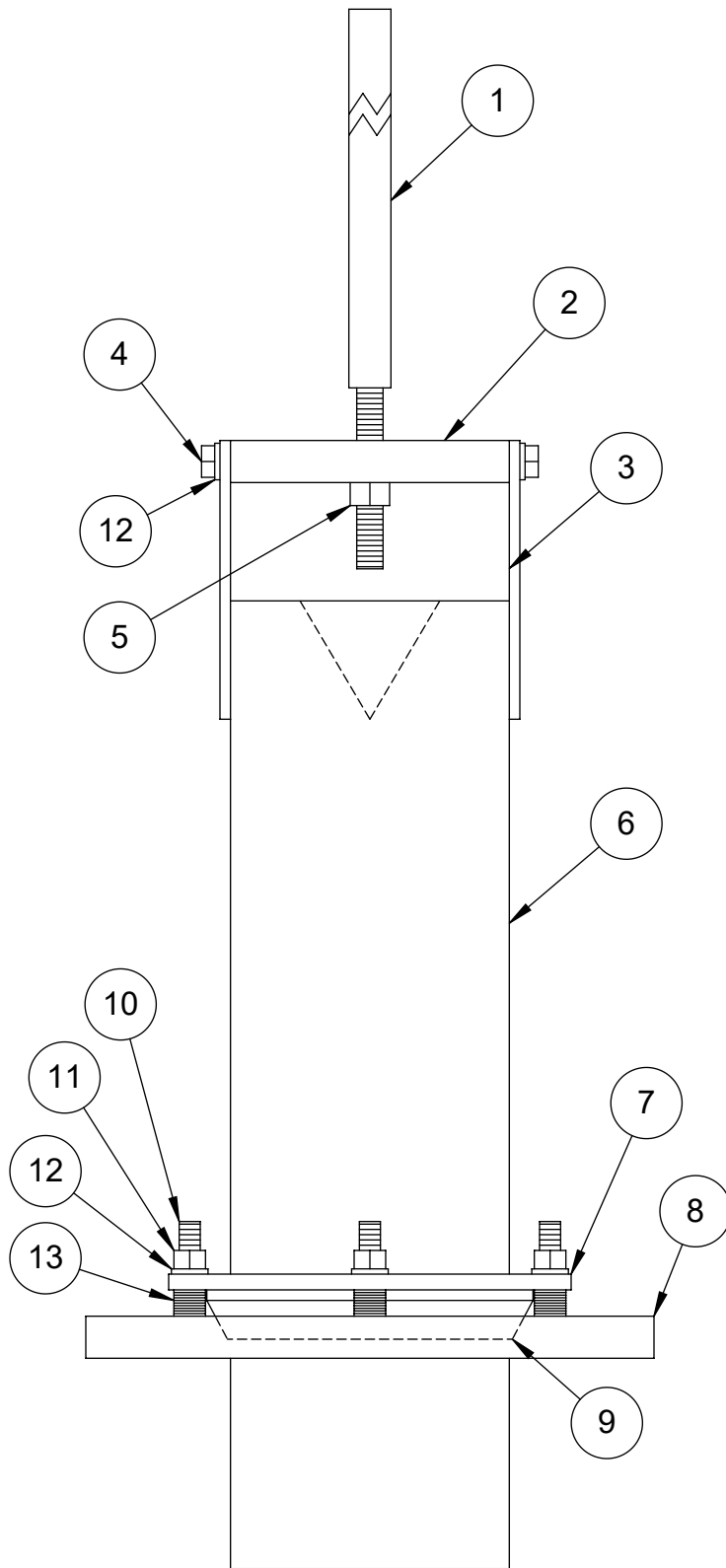

**Notes:**

- Pipe length is equal to Highwater Elevation minus Flange Elevation plus 12"
- Stem allows for minor adjustment
- Hardware material is determined by Slip Tube material
- V-Notch aids to reach Low Water and regulate flow

**SLIP TUBE**

- 304SS
- 316SS

**COMPANION FLANGE**

- CAST IRON
- 304SS
- 316SS

**V-NOTCH**

- REQUIRED
- NOT REQUIRED

**RISER PIPE NOMINAL SIZE**

\_\_\_\_\_



www.TroyValve.com

PHONE: 1-570-297-2125

227- DO NOT SCALE DRAWING

TITLE:

**Slip Tube Assembly**

MAT'L: See Above

DATE: 3/9/2021

PART NO:

**MTELEVLV-1**

DWN.

TE

PAGE: