

Item	Description	QTY.	MAT'L
1	Bushing	2	UHMW
2	End Plate	1	304SS
3	3/8-16 HHCS	2	18-8SS
4	Stem Guide	1	DI
5	1/2-13 HHCS	4	18-8SS
6	Flat Washer	8	18-8SS
7	Wall Bracket	1	DI
8	1/2-13 Locknut	4	18-8SS

Notes:

- Bushing size is per customer order (max bore is 2 1/2" solid rod)
- Minimum reach is 3 1/2"
- DI is A536 65-45-12
- A reach of 20" can be achieved by removing 2 bolts

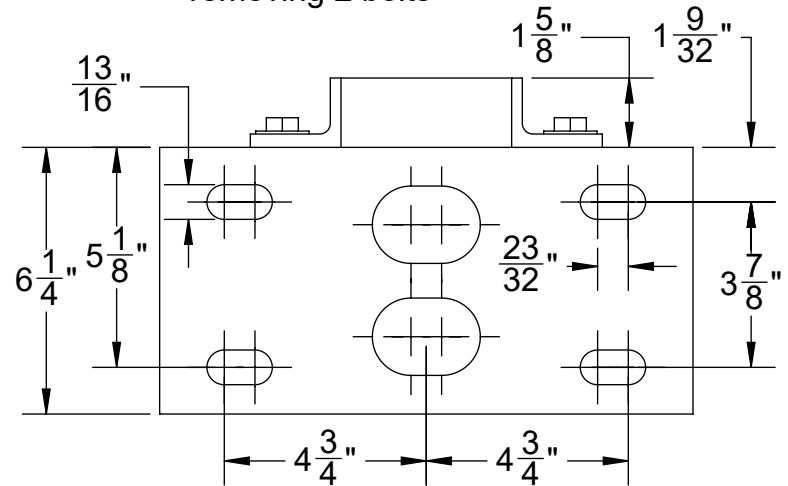

Mounting Detail

