

**DIMENSIONS ARE IN INCHES**

SIZE	18	20	24	30
A	28 1/4	30 1/2	35 3/4	43 9/16
B	1 9/16	1 11/16	1 7/8	1 3/4
C	32 7/16	36 15/16	41 7/8	45 7/8
D	1 1/4	1 1/4	1 3/8	1 3/8
E	14	18	18	24
F	22 3/4	25	29 1/2	36
G	25	28	35	44
H	8 1/2	9 5/8	11 7/8	14 7/8

Item	Description	QTY.	MAT'L
1	Frame	1	CI
2	Seat Ring	1	BRZ
3	Yoke	1	CI
4	Plug	1	CI
5	Resilient Seat	1	BUNA-N
6	Stem	1	BRZ
7	Stem Cap	1	CI
8	HHCS	7	SS
9	2" Wrench Nut	1	CI
10	Jam Nut	1	SS

**Notes:**

- Bubble tight resilient-to-bronze seating
- NSF Approved 2 part epoxy coating
- Open Left
- Valve Flanges must be level for proper operation
- 125# ANSI flange
  - Only the number of holes specified in the chart are used

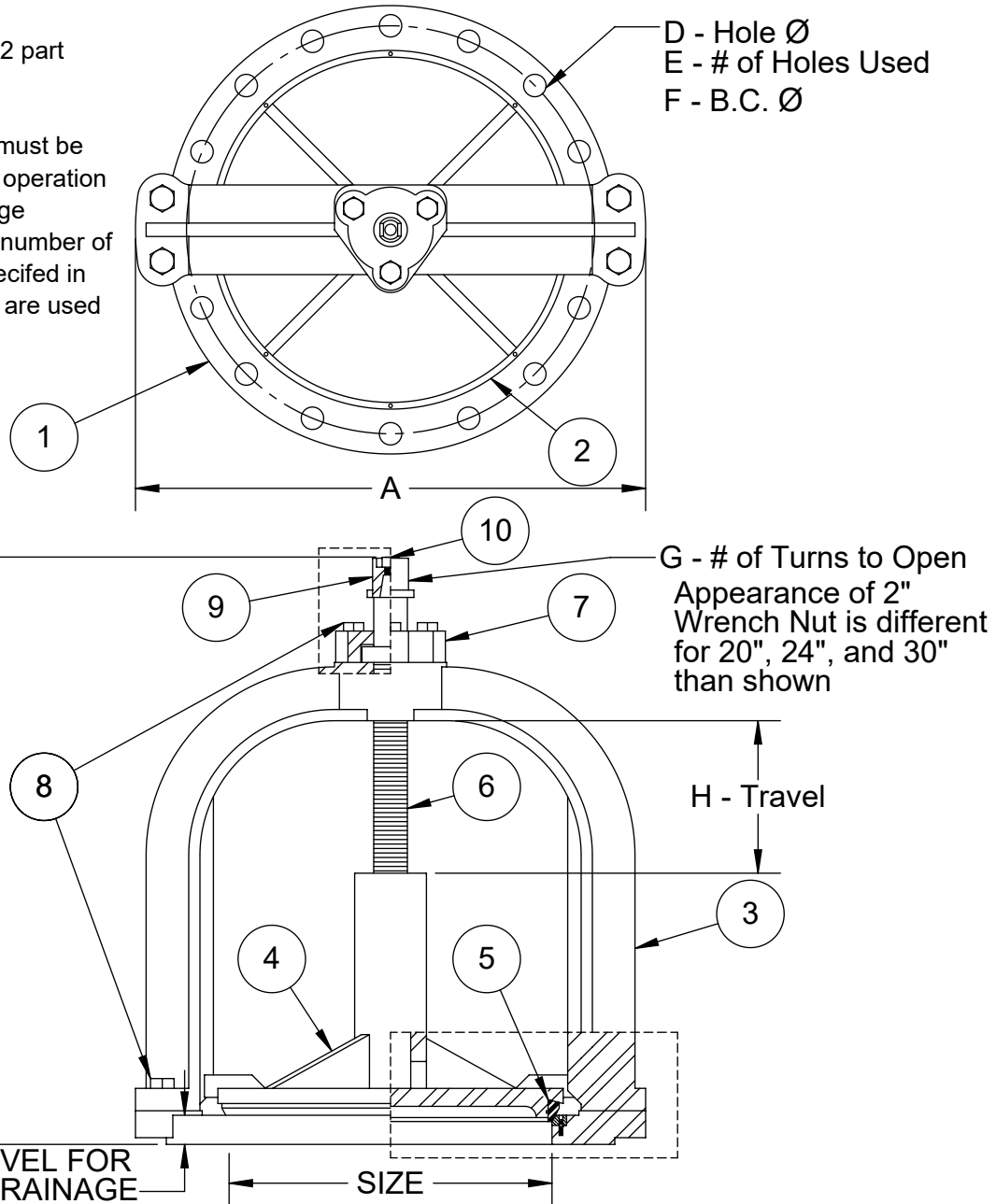

www.TroyValve.com

PHONE: 1-570-297-2125

1A6- DO NOT SCALE DRAWING

TITLE:

**CI Mud Valve - NRS 18" - 30"**

MAT'L:

CI

DATE:

8/21/2020

PART NO:

**A25600RB**

DWN.

TE

PAGE: